

# DonTronics DT.101 SimmStick™ Compatible SBC

The DT.101 can be configured in a variety of different ways depending on the application. The user only needs to install the components that best fits their needs.

## Minimally Required Components

**E1 Processor:** All of the following Microchip microcontrollers may be used: PIC16C52, 54, 56, 58A, 554, 556, 558, C61, 620, 621, 622, C83, C84, F84

**XTL1:** Either a standard microprocessor crystal or a three leg ceramic resonator with internal capacitors may be used for the system clock. Consult the Microchip data books for more information.

**Crystal:** If a crystal is chosen, C3 and C4 should be fitted with a pair of 15pf to 22pf ceramic capacitors.

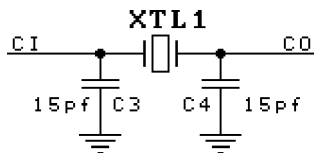

**Ceramic Resonator:** A three pin resonator may be installed at XTL1 facing either direction with no additional hardware.

## Features:

- \* Supports all of the Microchip PIC™ 16CXX line of microcontrollers in 18 pin DIP packages
- \* RS-232 level converter
- \* Brown out circuit protection
- \* Real Time Clock
- \* 1 to 64K Serial EEPROM
- \* 12 and 8 bit A/D converters
- \* Compatibility with the many SimmStick™ prototyping and expansion boards
- \* Compatible with the DT.001 programmer for on the fly in-circuit programming

**5V Power Supply:** Many of the SimmStick expansion boards provide a +5V supply so in some cases the power supply portion is optional. It can be disabled by opening jumper J1.

## 78L05 REGULATOR

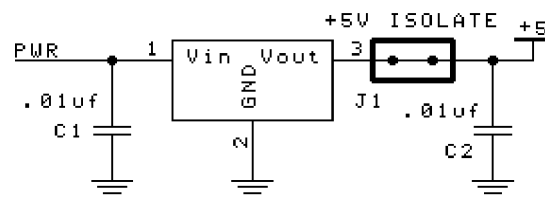

**R1, R2, and R3** are 10K, 1/4 W resistors that fulfill the reset requirements of the microprocessor.

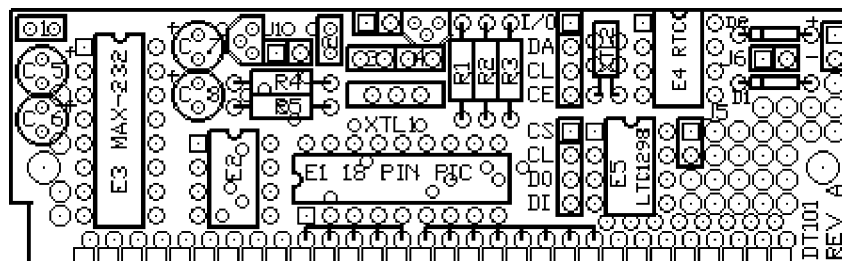

## Optional Components:

### Brown-Out Circuit:

The brown-out circuit is an IC in a TO-92 package used to stop the microcontroller operation from becoming unpredictable during power fluctuations. It is an added precaution for reliable operation and is not required in many cases. The older PIC16C5x, however may need the B/O.

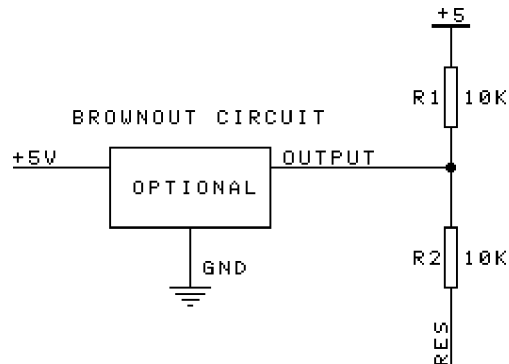

R1 and R2 should always be installed even if the B/O circuit is not used. The B/O IC should be CMOS or Open Collector type switching between 4.2 and 4.6 V for 5V operation.

Recommended B/O IC's:

Panasonic MN13811-S (Open Collector)

Panasonic MN1381-S (CMOS)

Zetek ZM33064

Motorola MC33064P

**E2 EEPROM** The DT.101 supports any of the Microchip serial 24LCxx type EEPROM's. The EEPROM is available in several sizes from 1 to 64 Kb. More information can be found on the Microchip Web Site.

R4 and R5 are 10K, 1/4 W pull-up resistors.

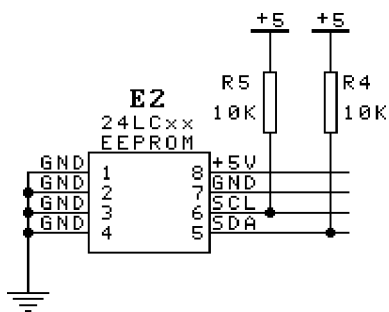

### E5 A/D Converter

DT.101 is compatible with several different serial 8 pin A/D converters including the 12 bit Linear Devices LTC1298 and the 8 bit National Semiconductor ADC0831. Wire jumpers should be connected between J3 and the appropriate free I/O pins to complete the hardware interface. AD+ and AD- are the analog inputs.

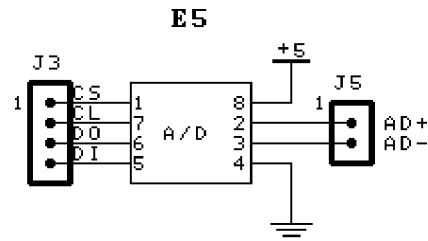

### RS-232 Level Converter

The RS-232 level converter circuit is composed of E3, a MAX-232 IC, and C5, C6, C7 and C8 1uF capacitors @ 16V. The SimmStick bus pins 1 and 2 are used for Tx and Rx respectively and may be hooked directly to PC's serial port or another DT.101 for serial communications.

### E4 Real Time Clock

The DT.101 supports the Dallas Semiconductor DS-1202/1302 or Panasonic NJU-6355 real time clocks. The clocks count seconds, minutes, hours, and the date even when the device is powered down provided an optional battery backup is connected using a watch type battery to J7.

The Panasonic NJU-6355 requires a 32.768kHz crystal with a load capacitance of 12pf installed at XTL2. The Dallas units need a 6pf crystal. Wire jumpers should be connected between J4 and the appropriate free I/O pins to complete the hardware interface.

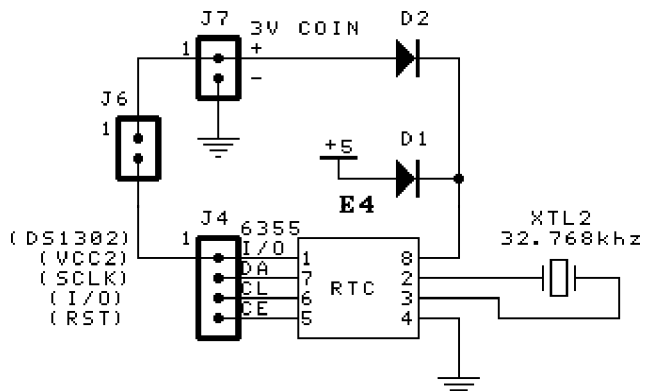

### Internet Resources:

Microchip PIC and EEPROM: <http://www.microchip.com/>

Linear Technology A/D's: <http://www.linear.com/>

Dallas Semiconductor RTC's: <http://www.dalsemi.com/>

National Semiconductor A/D's: <http://www.national.com/>

DonTronics RTC Examples: <http://dontronics.com/rtc.html>

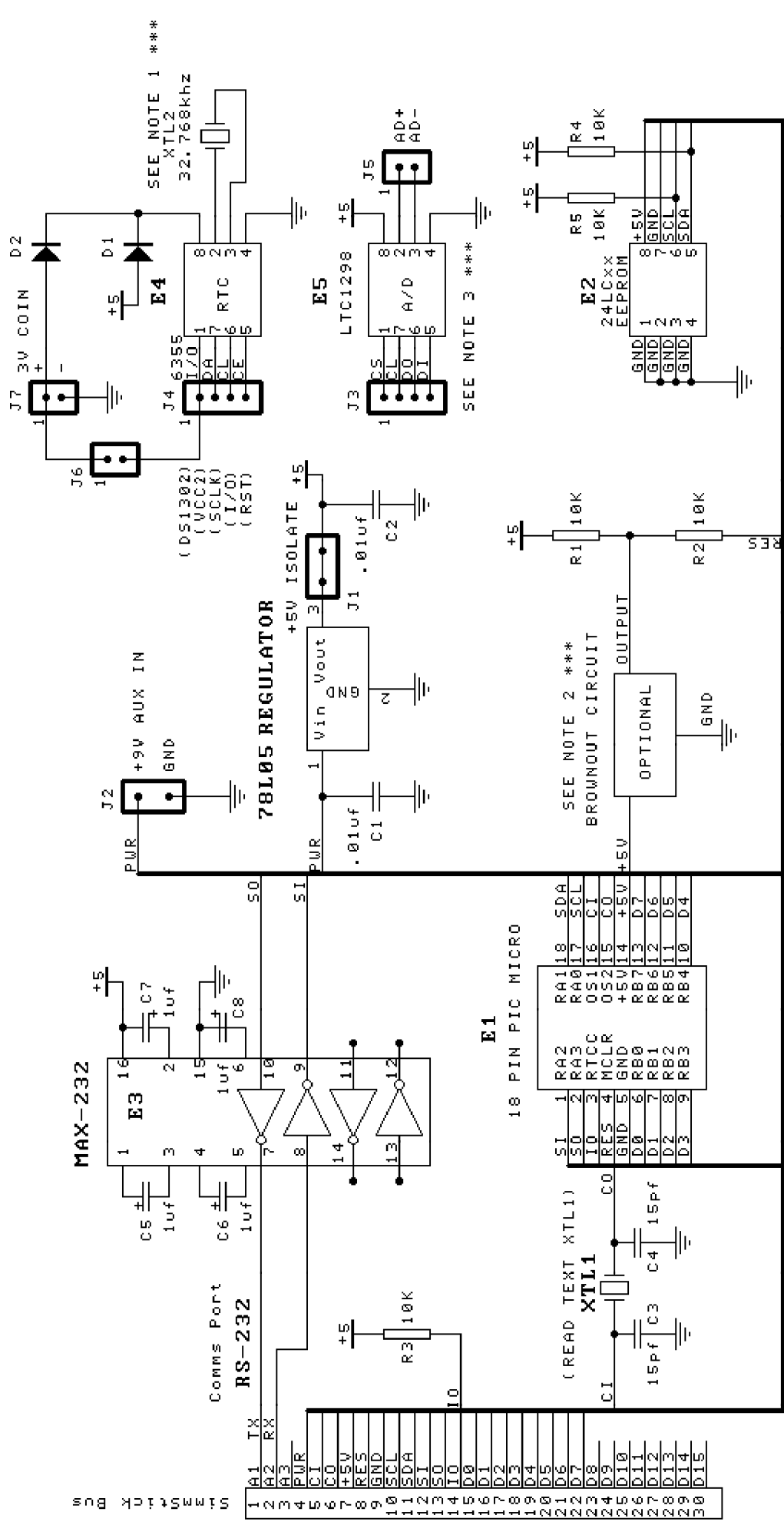

DonTronics 1997(c)

Title		Revision	
Size	A4	Sheet 1	of 1
Date:	9-JUN-1997	Drawn:	ByDon_MCK
File:	DT101A/1		

DT101 Rev. A